

CARSUPPORT	<u>STANDARD</u>	<u>HEAVY DUTY</u>
	24S05	24S05H

MAKE: TYPE: YEAR:
Kia **Sportage** **'04-'10**

CAR HEIGHT

After fitting the rear of the car will raise:

- Standard set approx. + 20 mm
- Heavy duty set approx. + 30 mm

LOCATION (see letter in set number)

"S": on shock absorber or strut

PARTS

- (1) 2x upper seat
- (2) 2x auxiliary spring
- (3) 2x lower seat with dust cover
- (4) 2x steel cover
- (5) 2x rubber collar

- (A) original upper seat
(B) original bumpstop

INSTRUCTIONS

1. Inside the vehicle:
 - Remove the covers (L/R) of the trunk side lining
 - Loosen the nuts of the upper side of the strut
2. Jack up the rear of the vehicle and remove the rear wheels
3. Disconnect the stabilizer link and the ABS-cable brackets from the strut.
4. Support the brake disc and disconnect the lower end of the strut. Then disconnect the upper side of the strut.
5. Remove original upper spring seat(A) and main spring using a spring compressor.
ATTENTION: Mark the position of the upper seat with respect to the lower seat for easy installation.
6. Remove bumpstop(B) from the original dust cover. The original dust cover will not be re-used
7. Place rubber collar(5), steel cover(4), lower seat with dust cover(3), auxiliary spring(2), bumpstop(B) and upper seat(1) on the strut
8. Place main spring and upper seat(A)
9. Reconnect the upper side of the strut to the vehicle, then reconnect the lower side, ABS-cable brackets and the stabilizer link.
10. Place the rear wheels and lower the vehicle.
11. Tighten the nuts inside the vehicle and place the the covers (L/R) of the side lining.

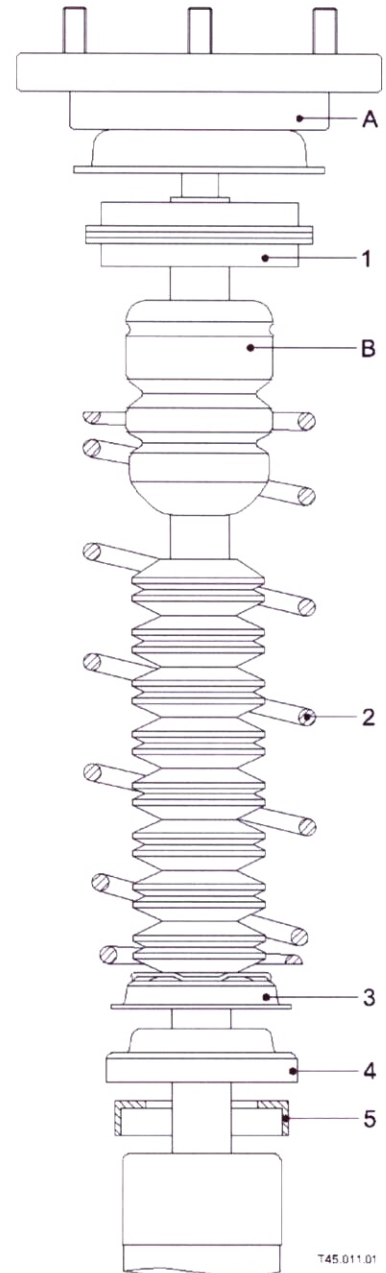

T45.011.01